

TECHNICAL SPECIFICATIONS

PCR Canister: 100% recycled material
2.5, 3, 5, 10, 20 and 20 liter

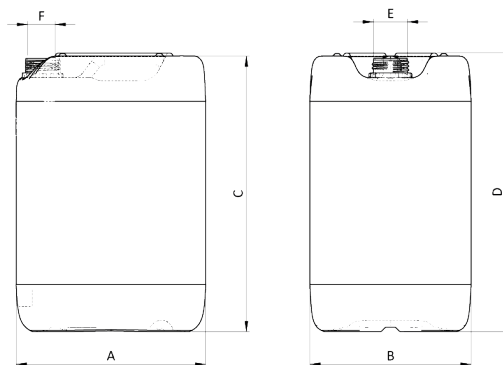

Article name	Nominal volume (L)	Weight (g)	Packaging unit		Approx. dimensions in mm					
			per PU	per pallet	A	B	C	D	E	F
02,550-K4 rHDPE black	2,5	180	40	440	188	116	165	180	DIN 50	41
0350-K4 rHDPE black	3	200	40	400	188	116	190	205	DIN 50	41
0550-K6 rHDPE black	5	270	30	240	180	145	224		DIN 50	41
1050-K6 rHDPE black	10	480	20	120	230	190	300		DIN 50	41
2060-KE rHDPE black	20	1200	12	60	290	252	370	375	DIN 60	48
3060-KE rHDPE black	30	1500	12	48	290	252	500	505	DIN 60	48

MATERIAL

- 100% in-house rHDPE (internally recycled HDPE from our own previous production processes)
- Masterbatch

ADVANTAGES

- Sustainable solution made from 100% in-house recycling material
- CO₂-reduced material
- Swiss quality
- Stable and consistent material quality due to controlled internal recycling
- More cost-effective than virgin HDPE or external PCR materials
- Internal circular-economy concept

DESIGN

- Standard version black
- Visibility stripes available upon request (only possible from 5 liter)

APPLICATIONS

- Technical liquids
- Cleaning chemicals
- Construction chemicals
- Industrial applications

ENVIRONMENT

- Recycling of non-contaminated HDPE possible
- HDPE can be destroyed without any adverse consequences
- Effective removal of residues is guaranteed
- Dyes are free of heavy metals

PRODUCTION / QUALITY ASSURANCE

- ISO 9001 certified
- Low-germ filtered blowing air
- Controlled manufacturing (particles, microbiology, migration)
- Hygiene standards
- No UN approval available

STORAGE STABILITY (WITHOUT FILLING MATERIAL)

- When stored correctly (dry, protected from sunlight, between 5 °C and 30 °C): shelf life of up to two years

CLOSURE & TIGHTENING TORQUE

- Screw cap art. 4538 DIN 50-D-PE/G black SR
- tightening torque 8 – 12 Nm
- Screw cap art. 4557 DIN 60-D-PE/G black SR
- tightening torque 12 – 14 Nm

PALLETIZATION

- Euro pallet (Class A) 80 x 120 cm
- 02,550-K4 pallet height approx 205 cm
- 0350-K4 pallet height approx 215 cm
- 0550-K6 pallet height approx. 215 cm
- 1050-K6 pallet height approx. 200 cm
- 2060-KE pallet height approx. 200 cm
- 3060-KE pallet height approx. 220 cm